

INSERT DUMP BED

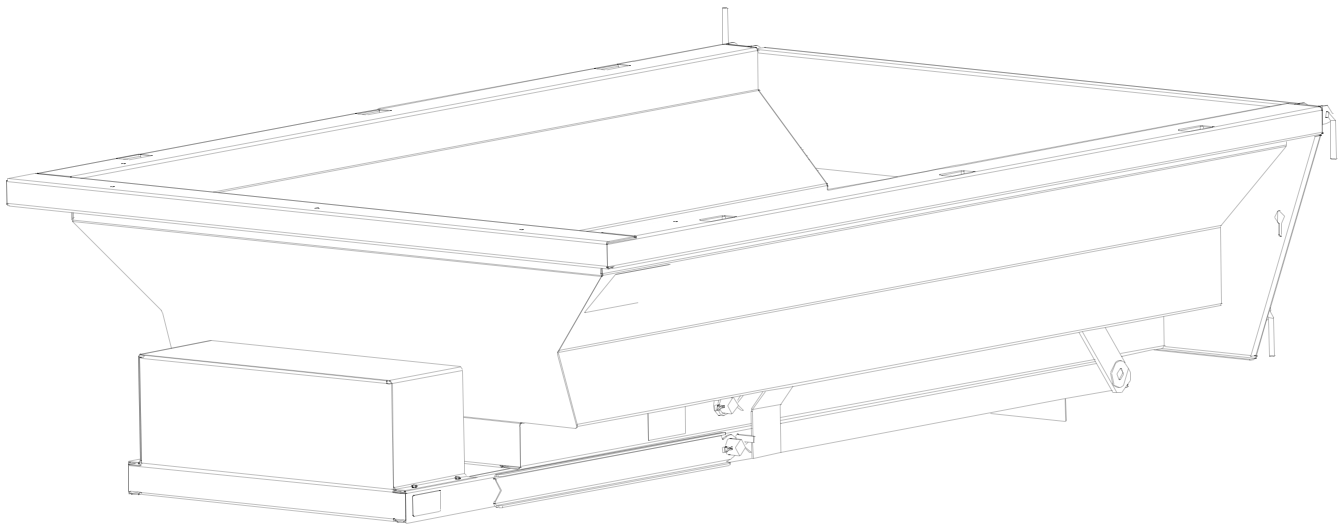

MAGNUMTM

Contents

TABLE OF CONTENTS.....	2
SAFETY.....	3-5
MOUNTING AND OPERATING INSTRUCTION.....	6
ELECTRIC PUMP WIRING INSTRUCTIONS.....	7-8
DUMP BED MAINTENANCE.....	10-11
DUMP BED PART LISTING.....	12-20
SUBFRAME.....	21
HYDRAULIC PUMP PARTS LISTING.....	22-23
HOIST PARTS LISTING.....	24-28
CAB SHIELD.....	29
WARRANTY.....	30

INSERT DUMP BED INSTALLATION AND OPERATING INSTRUCTION MANUAL

SAFETY PRECAUTIONS

The best safety device is a careful operator!



This symbol means **ATTENTION!**
Become Alert!
Your safety is involved!
Please read and understand completely before doing!

BEFORE PERFORMING MAINTENANCE OPERATIONS, PARK VEHICLE ON LEVEL GROUND. SET PARKING BRAKE, SHUT OFF ALL POWER, AND MAKE SURE ALL MOVEMENT HAS STOPPED. IF BODY IS RAISED, IT MUST BE SECURELY BLOCKED SO IT CANNOT COME DOWN. SUPPORT BLOCKS MUST NOT BE REMOVED UNTIL THERE IS NO DANGER OF ANYONE BEING UNDER BODY WHEN BODY IS LOWERED.



Improper use of this equipment can result in serious injury. To reduce this possibility, give complete and undivided attention to the job at hand, and follow these safety precautions.

PREPERATION:

Know your controls. Read this instruction manual. Learn how to stop the equipment quickly in an emergency.

Do not allow children to operate machine; nor adults to operate it without proper instructions.

Keep all individuals not involved in the use of the equipment a safe distance away.

A copy of this manual should be available in the cab at all times. A copy may be obtained from your local dealer or download from www.mangumproducts.com.

OPERATION:

Do not exceed rated capacities of chassis or hoist.

Observe and shut off all equipment controls before starting engine so equipment will not unintentionally operate when engine is started.

Always check area around machine before engaging or operating controls.

Vehicle should be on a flat surface prior to raising bed. Operation on slippery uneven terrain may result in equipment damage or personal injury.

Know the material you are hauling and plan your haul to avoid "set up" or freezing of the load in the dump body. In the event that a load becomes stuck or frozen in the body, do not abuse, overload, or damage the truck, hoist, or body in efforts to quickly free the load. It may be necessary to thaw indoors to safely remove such a load.

In the event that shoveling or mechanical means are used to free the stuck load, be sure the load is NOT hoisted and the tailgate, if opened, is secured properly before starting this effort. If hoisted, a stuck load, or portion, could release unexpectedly and cause injury to personnel or damage to the body, truck, or surroundings.

Some materials such as mud, or sludge, may shift easily when wet, resulting in increased tendency to overturn the truck on curves, unstable ground, or side slope situations. Reduce load size, speeds, and side slopes, and use care and planning to avoid this potential occurrence.

Unload the body and securely prop and block a raised body before any service, inspection, or repair work is started.

Be sure the PTO is disengaged before traveling. Failure to disengage the PTO from driving the pump/valve when in transit may allow the dump body to rise unintentionally. This may lead to loss of vehicle control, accidental injury and/or property damage.

Lift points are provided to safely lift body assembly. Never lift or handle loaded body, empty material prior to handling the body.

Always wear relatively tight and belted clothing when operating equipment. Loose jackets, shirts sleeves or other loose clothing should not be worn because of the danger of catching them in moving parts or controls.

Stop and inspect equipment if unusual movement, sounds, or noises are observed. Repair damage before restarting and operating the equipment.

Disengage power to all operating equipment: (1) before leaving operator's position, (2) before making any repairs or adjustments, or (3) when not in use.

Take all possible precautions when leaving the equipment unattended; such as disengaging the hydraulic system, shifting vehicle out of gear, setting parking brake, shutting off engine and removing key. Never leave raised body unattended.

SAFETY DECALS

NOTICE:

1. It is the responsibility of the Owner of the Dump Bed to replace any or all safety decals which become unreadable or otherwise defaced.
2. Read and observe all “Danger” and “Caution” safety decals appearing on equipment.

The following safety decals appear in various locations on your Dump Bed, refer to page 6 for approximate locations.

The sizes of the decals shown in this manual have been reduced in order to save paper space. Each decal has dimensions listed for actual sizes.



This decal alerts all to the danger of being under a raised Dump Bed where serious personal injury could result if the bed were to come down.

This decal also alerts the operator to precautions necessary to eliminate other dangerous situations associated with a raised bed.

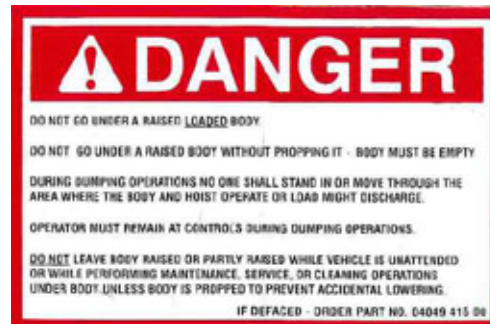

This decal alerts all to the danger of being under a raised Dump Bed where serious personal injury could result if the body were to come down.

This decal also alerts the operator to precautions necessary to eliminate other dangerous situations associated with a raised bed.

INSERT DUMP BED SAFETY DECAL LOCATION

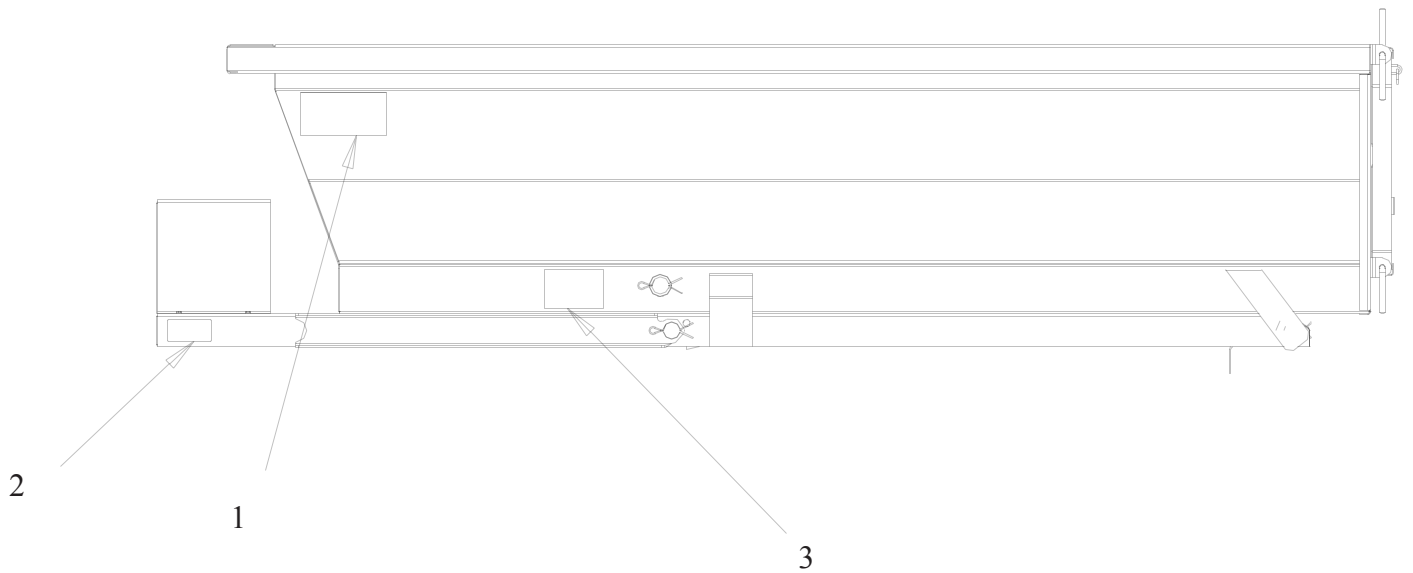

Item	Part Number	QTY	Description
1	64093	2	Decal, Large, Danger
2	62571	1	Decal, Serial No.
3	64094	2	Decal, Small, Danger

MOUNTING AND OPERATING INSTRUCTIONS



CAUTION!

MAKE SURE TRUCK IS ON LEVEL GROUND AND BRAKES ARE SET.



WARNING!

BEFORE RAISING DUMP BED MAKE SURE AREA AROUND TRUCK IS CLEAR OF PEOPLE

DUMP BED MOUNTING

1. Make sure the truck being used is on level ground.
2. Remove tailgate from truck.
3. Position dump bed into truck bed with rear channel of sub frame flush against rear of truck bed.
4. Ensure dump bed is centered between sides of truck bed.
5. Determine best position to drill holes in rear channel and truck bed to attach.

10. When everyone is clear of the truck, raise the dump bed high enough to engage the safety prop. Lower the dump bed so that the prop properly engages the prop pocket and is supporting the full weight of the dump bed. Remove power.



WARNING!

DO NOT WORK UNDER THE DUMP BED WITHOUT HAVING THE SAFETY PROP POSITIONED PROPERLY IN THE PROP POCKET



CAUTION!

CHECK FOR CLEARANCES OF WIRING OR OTHER OBSTACLES BEFORE DRILLING ANY HOLES.



CAUTION!

CHECK FOR CLEARANCES OF WIRING OR OTHER OBSTACLES BEFORE DRILLING ANY HOLES.

6. Drill two (2) 13/32 inch hole to accommodate the 3/8 inch bolts. See PHOTO #1 next page.

7. Attach dump bed to truck bed using the supplied 3/8 inch bolts, nuts and washers.

8. Attach negative side of jumper cable to the dump bed and the positive side to solenoid on pump. The truck frame can be used as a temporary ground.

9. Cut and remove the shipping straps at the front of the dump bed and hook loose end of power cable to positive terminal of truck battery.

11. Drill a 13/32 inch hole in the front support channel. See PHOTO #2 on next page.

12. Attach the front support channel to the truck bed using the 3/8 inch bolt, nut and washer.

13. For added support place the 4 inch plate between the under side of the truck bed and the nut.

NOTE: Since trucks models vary, if the bolts provided are not of correct length, GRADE 5 bolts can be purchased from most local hardware and farm supply stores.

INSERT DUMP BED INSTALLATION AND OPERATING INSTRUCTION MANUAL
MOUNTING AND OPERATING INSTRUCTIONS CONT'D

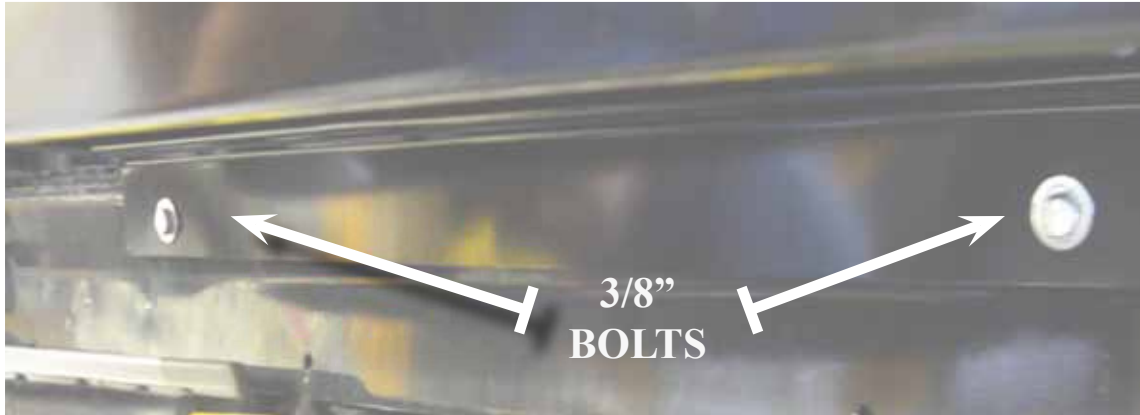

PHOTO #1

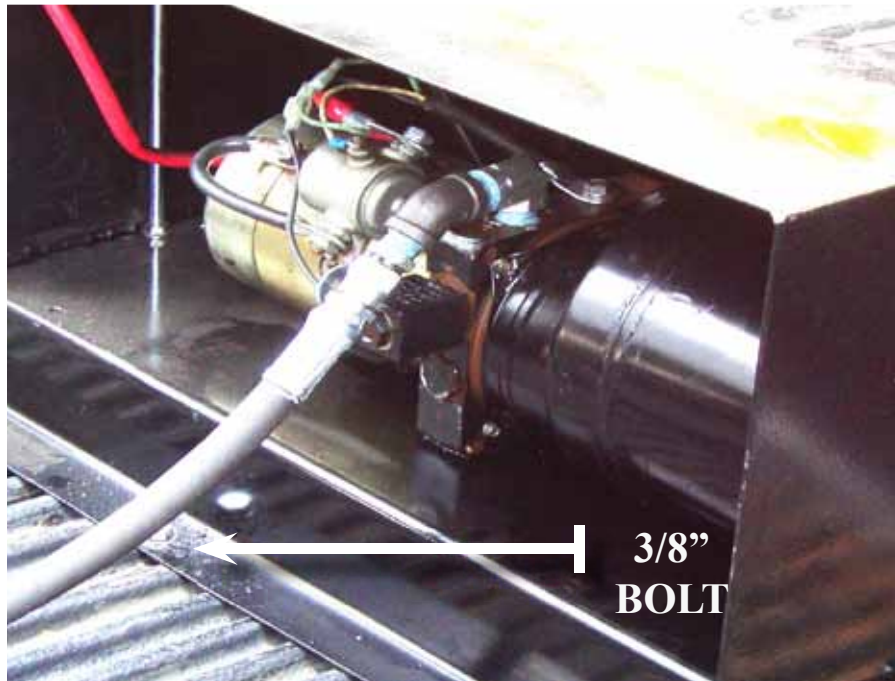

PHOTO #2

ELECTRIC PUMP WIRING INSTALLATION INSTRUCTIONS



WARNING!

USE SAFETY GLASSES OR OTHER SUITABLE FACE PROTECTION AGAINST POSSIBLE BATTERY EXPLOSION . DO NOT SMOKE AND AVOID OTHER SOURCES OF IGNITION

NOTE: Use dielectric grease on all electrical connections. Keep all wires away from sharp, hot or moving parts.

1. Find a suitable mounting location for the circuit breaker/ relay panel inside the engine compartment in an area that is dry and protected from road splash. Mount panel with self-tapping screws.
2. Cut red battery cable to length from battery to circuit breaker and attach copper eyelets. Attach the battery cable to the circuit breaker terminal marked BAT. (DO NOT ATTACH TO BATTERY AT THIS TIME)
3. Attach copper eyelets to remaining RED battery cable and route harness from the circuit breaker along truck frame, up into truck bed to electric pump solenoid. Attach to power side of solenoid.
4. Attach copper eyelets to BLACK cable of the truck side wiring harness, then attach to the GRD bolt on pump frame. Route BLACK cable from pump through frame to battery. Excess cable must be coiled and secured. (DO NOT ATTACH TO BATTERY AT THIS TIME.)



CAUTION!

MAKE SURE TO ROUTE BATTERY CABLE CLEAR OF PINCH POINTS, SHARP EDGES AND HEAT SOURCES.



WARNING!

BEFORE CONNECTING BATTERY CABLES, ENSURE AREA IS CLEAR OF PERSONS AND EQUIPMENT

5. Connect RED (longer) cable to the circuit breaker/relay panel.
6. Connect BLACK spreader side wiring harness to the battery. Excess cable must be coiled up and secured.
7. Connect Red (shorter) cable to battery. The hydraulic pump is a one directional design.
8. Dump is now ready for test.

DUMP BED MAINTENANCE

MAINTENANCE SCHEDULE

1. Check hydraulic fluid. If additional fluid is required, add Dextron ATF oil.

The fluid should not need to be changed unless it becomes contaminated from an outside source.

To check the fluid level, use the following steps.

- a. Remove breather cap.
- b. Insert small ruler until it touches bottom of reservoir.
- c. Depth of fluid should measure approximately 5 inches. on ruler.
- d. Add in small amounts if additional fluid is required.

DO NOT OVER FILL.

2. Lubricate the following grease fitting locations every 3 to 6 months, depending on use.

SEE 12 POINT GREASE FITTING LOCATOR CHART ON FOLLOWING PAGE AS GUIDE TO LUBRICATION POINTS.

INSERT DUMP BED INSTALLATION AND OPERATING INSTRUCTION MANUAL
MAINTENANCE GREASE POINT LOCATION GUIDE



PARTS LISTING AND PRODUCT VIEWS

REAR VIEW

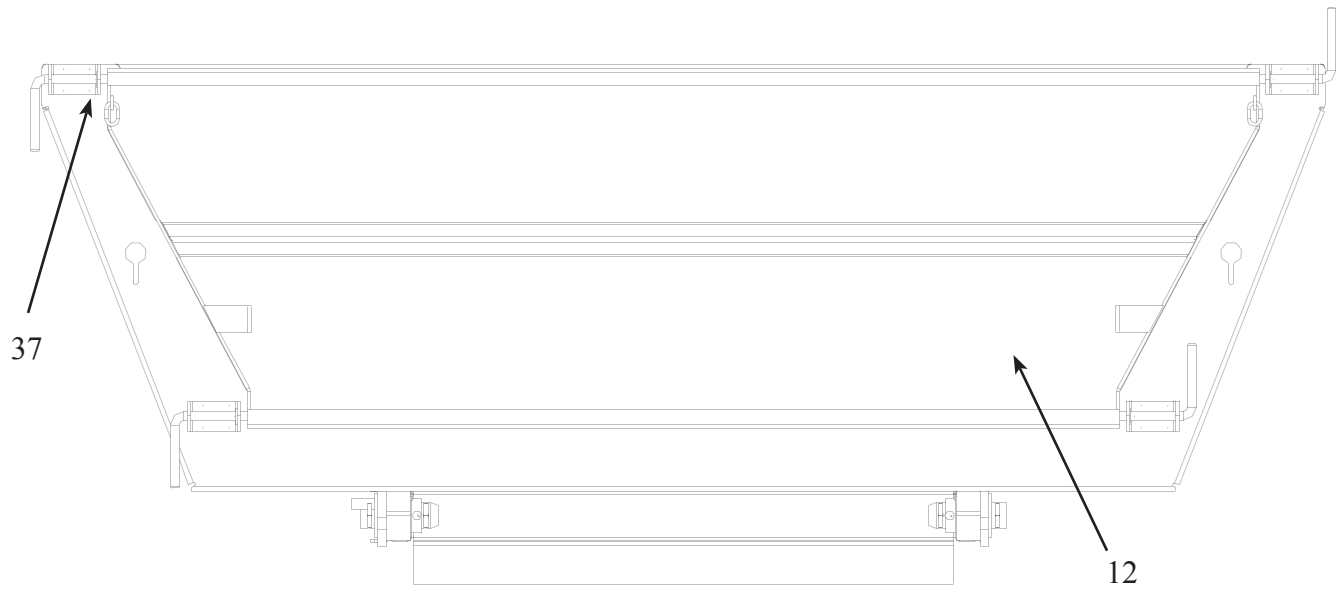

FRONT VIEW

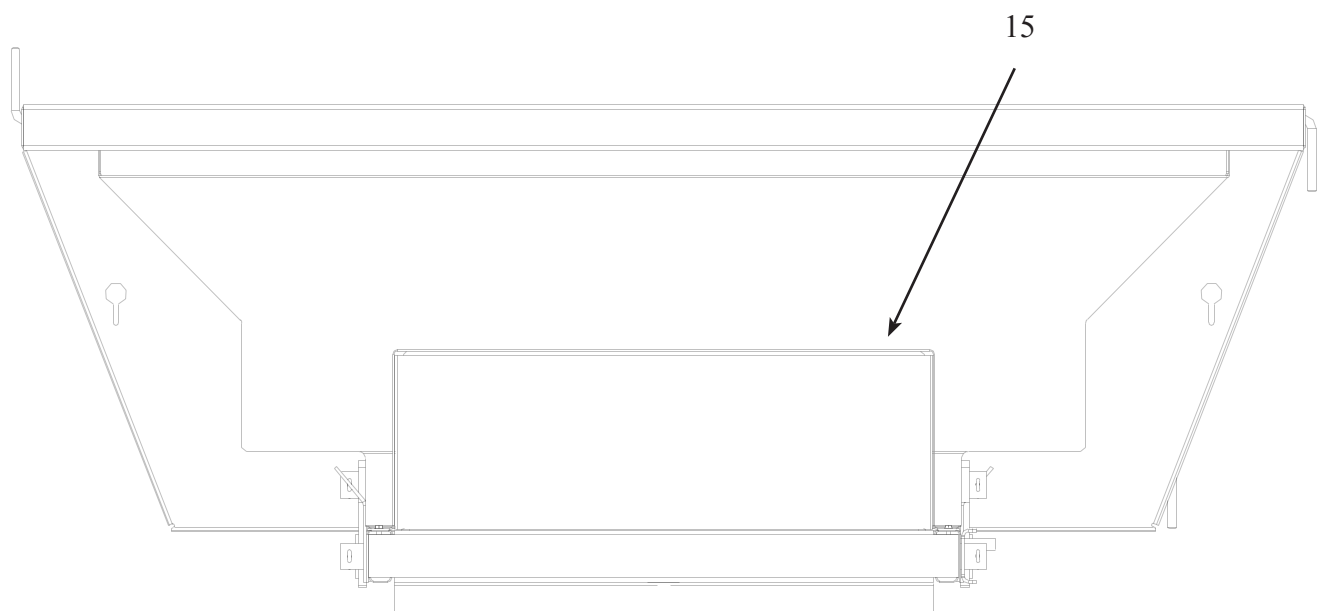

PARTS LIST

ITEM	PART NUMBER	QTY	DESCRIPTION
12 CS	64095	1	WELD, TAILGATE CS
SS	64096	1	WELD, TAILGATE, S3
CS	64253	1	WELD, TAILGATE, CS 14g
15 CS	64097	1	WELD, COVER PUMP
37	64098	4	LATCH, SPRING

SIDE VIEW

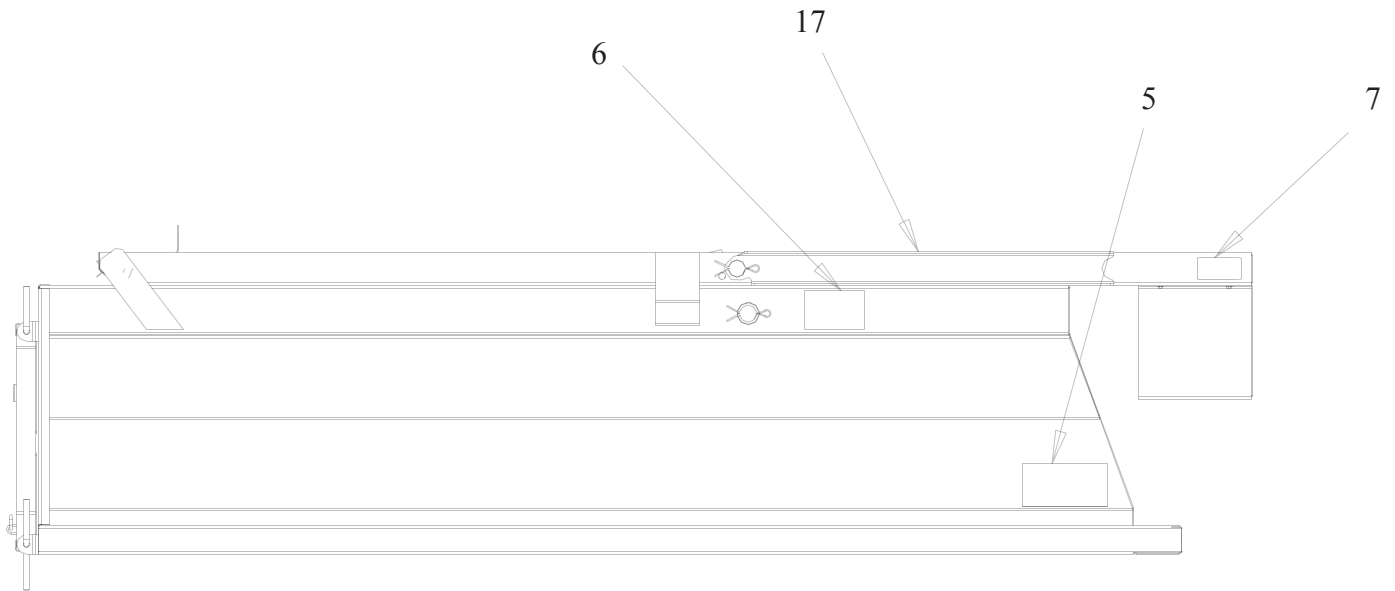
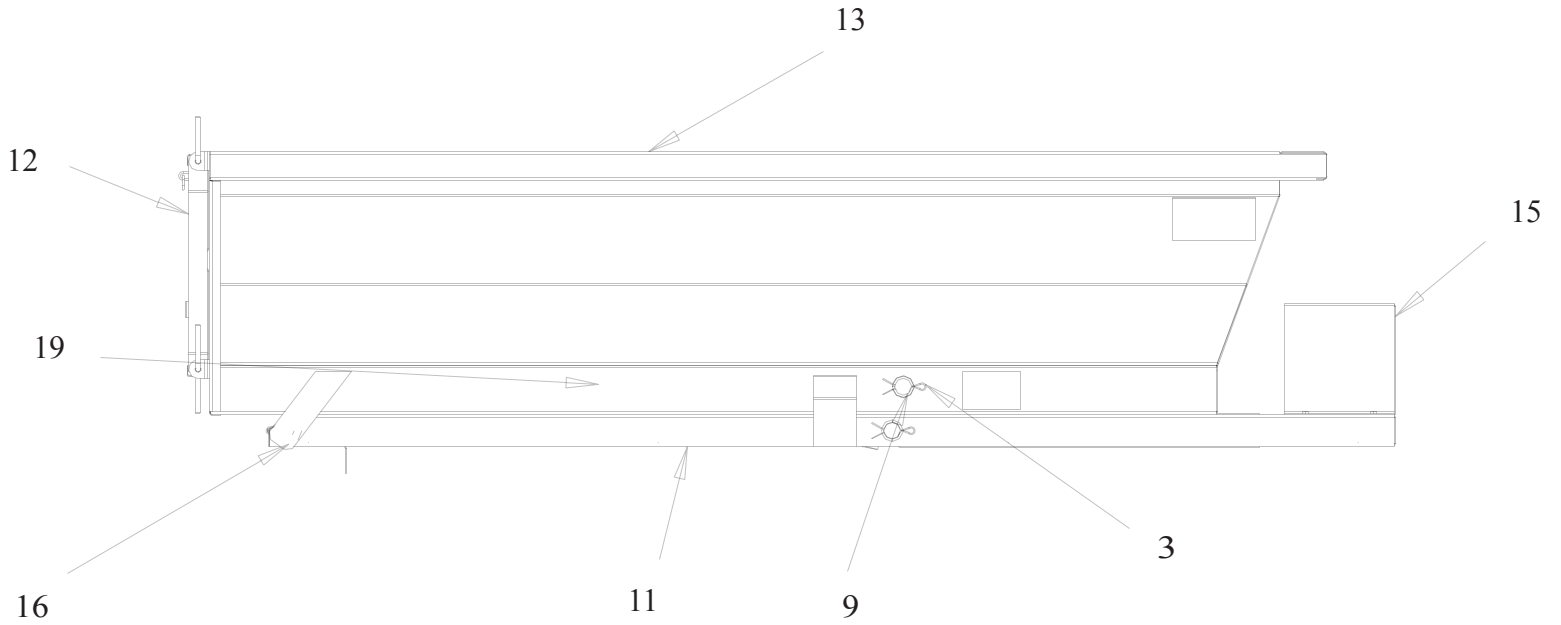

PARTS LIST

ITEM	PART NUMBER	QTY	DESCRIPTION
3	64099	10	COTTER PIN 1/4" X 3"
5	64093	2	DECAL, LARGE DANGER
6	64094	2	DECAL, SMALL DANGER
7	62571	1	DECAL, SERIAL NUMBER
9	64100	2	SHAFT, PIVOT
11	64110	1	SUB-FRAME, 8 FT. DUMP
	64250	1	SUB-FRAME, 6.5 FT. DUMP
12	CS 64095	1	WELD, TAILGATE CS
	SS 64096	1	WELD, TAILGATE, S3
	CS 64253	1	WELD, TAILGATE, CS, 14g
13	CS 64101	1	WELD, BODY
	SS 64102	1	WELD, BODY
	CS 64248	1	WELD, BODY, 14g 6.5 FT. DUMP
	SS 64249	1	WELD, BODY, 14g 6.5 FT. DUMP
15	CS 64097	1	WELD, COVER PUMP
16	64103	2	WELD, HINGE PIN SHORT
17	64104	1	WELD, PROP ROD, 8 FT. DUMP
	64254	1	WELD, PROP ROD, 6.5 FT DUMP
19	64105	1	WELD, UPPER HOIST

BOTTOM VIEW

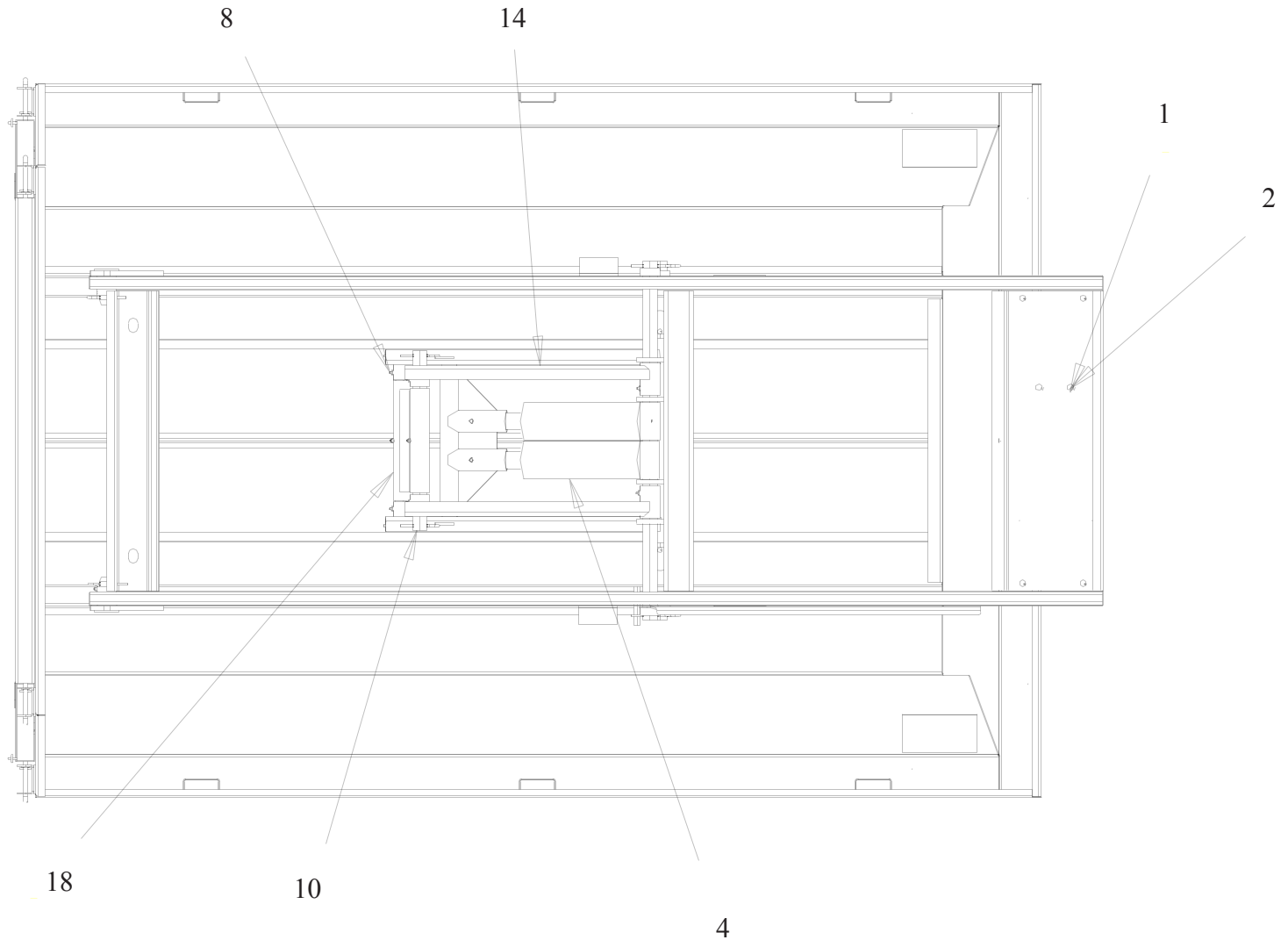

PARTS LIST

ITEM	PART NUMBER	QTY	DESCRIPTION
1	20353	2	3/8" FLAT WASHER ZP
2	63558	6	3/8" - 16 X 1" HH BOLT ZP
4	64106	2	CYLINDER, HYDRAULIC
8	61236	12	GREASE FITTING
10	64107	2	SHAFT, PIVOT
14	64108	2	WELD, CHANNEL, LOWER HOIST
18	64109	1	WELD, PIVOT ASSEMBLY

BOTTOM VIEW

SINGLE CYLINDER 6.5 FT DUMP

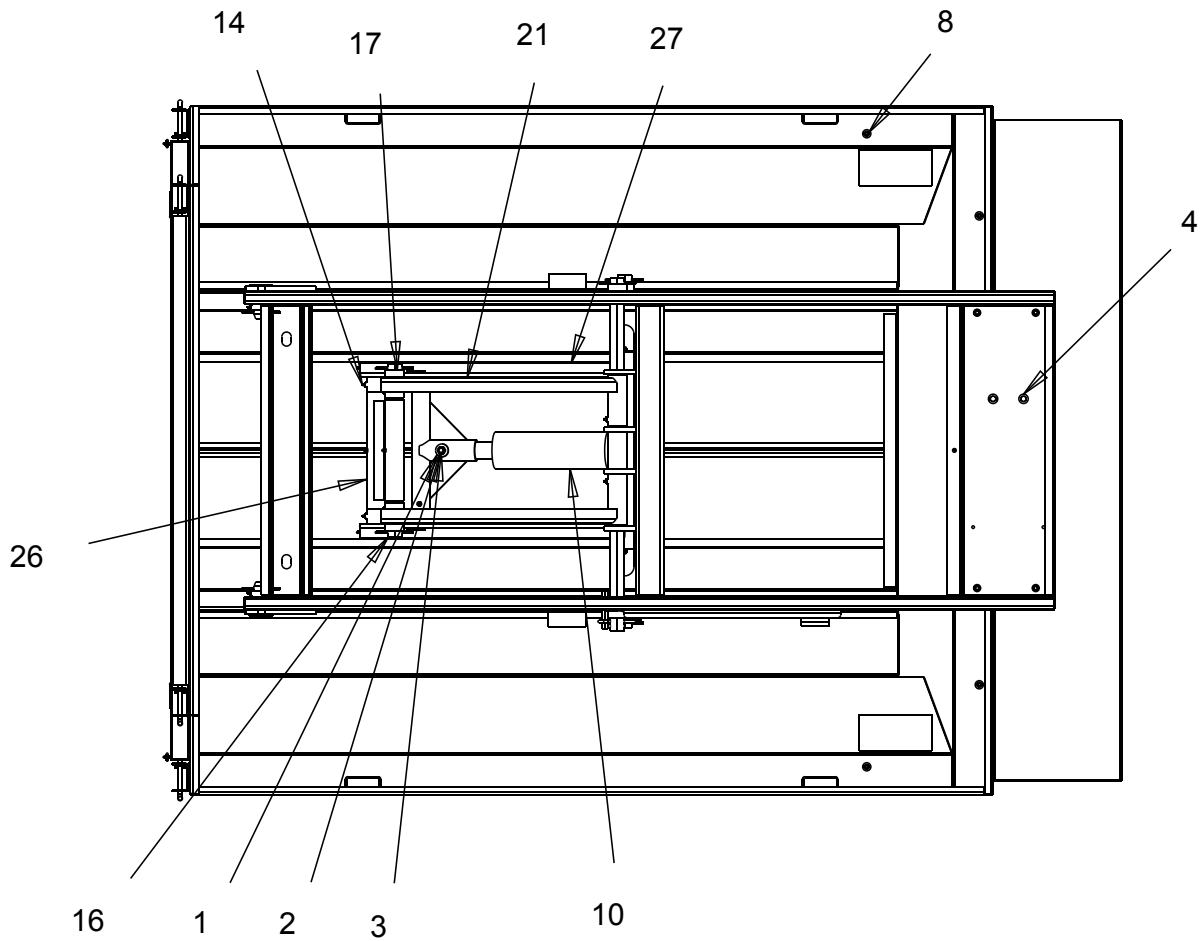

PARTS LIST

ITEM	PART NUMBER	QTY	DESCRIPTION
1	20355	2	1/2" FLAT WASHER ZP
2	63278	1	1/2"-13 CEN LOCKNUT ZP
3	64255	1	1/2"-13X3" HH BOLT ZP
4	20353	2	3/8" FLATWASHER ZP
8	64256	5	5/16" - 18 NYLON LOCKNUT ZP
10	64106	1	CYLINDER HYD
14	61236	13	GREASE FITTING
16	64107	2	SHAFT, PIVOT
20	64257	2	WELD CHANNEL LOWER HOIST
25	64109	1	WELD, PIVOT ASSEMBLY
26	64258	1	WELD, UPPER HOIST

SUB-FRAME

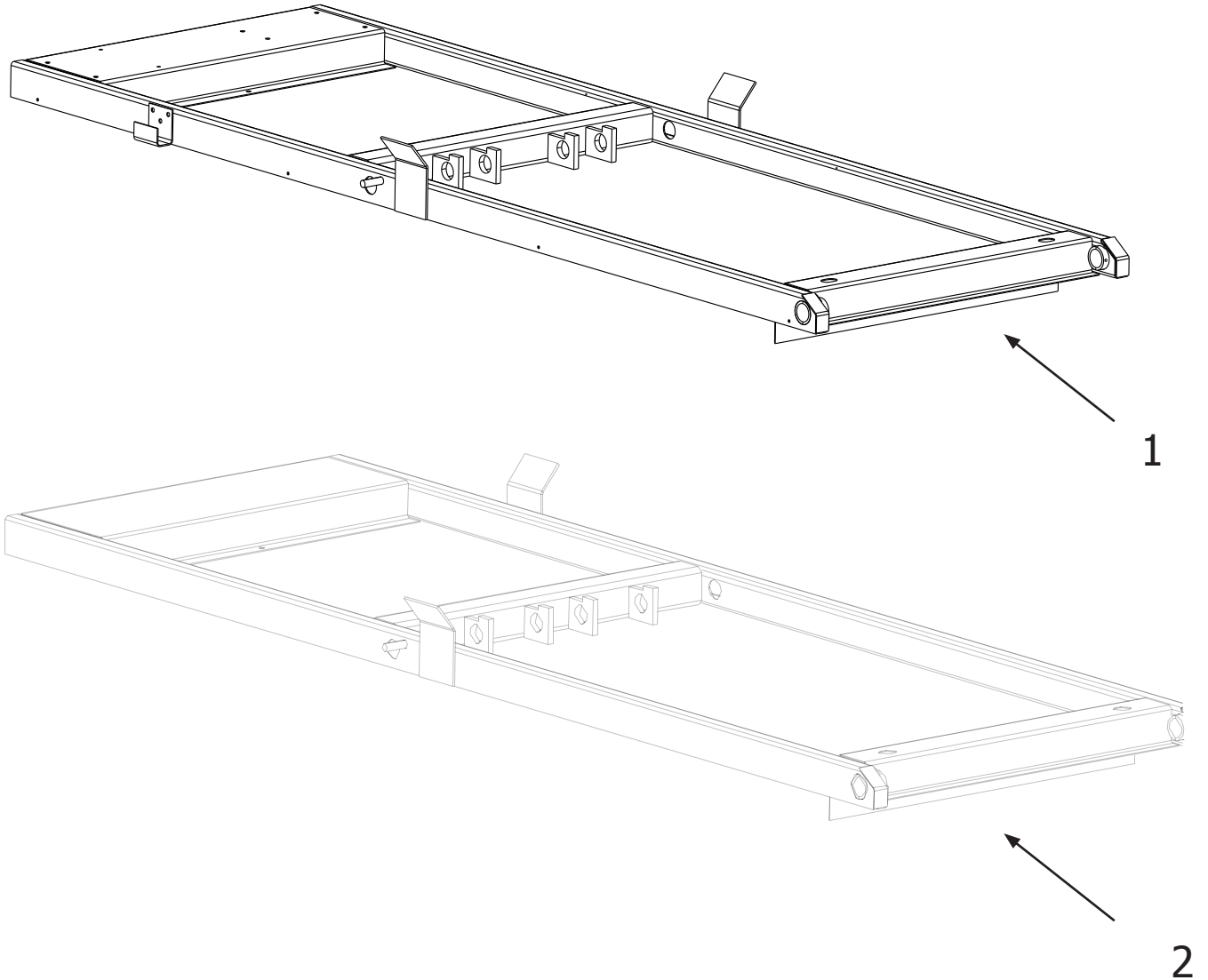

ITEM	PART NUMBER	QTY	DESCRIPTION
1	64110	1	WELD, SUB-FRAME TWIN CYLINDER
2	64250	1	WELD, SUB-FRAME SINGLE CYLINDER

HYDRAULIC PUMP 64111

DIMENSIONS AND PARTS LISTING

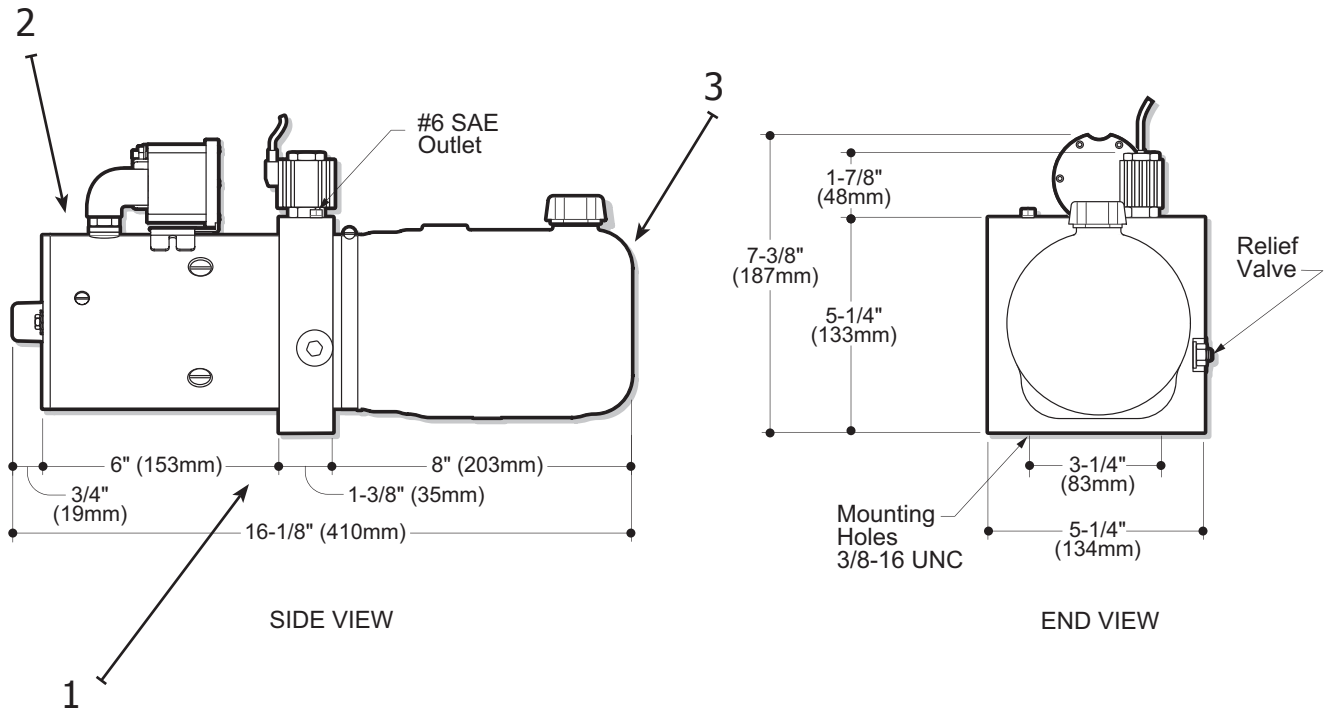

ITEM	PART NUMBER	QTY	DESCRIPTION
1	64111	1	PUMP, HYDRAULIC/ELECTRIC W/ RESERVOIR
2	64112	1	PUMP ONLY, HYDRAULIC/ELECTRIC
3	64113	1	TANK ONLY, PUMP, HYDRAULIC/ELECTRIC

HYDRAULIC PUMP CONT'D

SOLENOID WIRING DIAGRAM

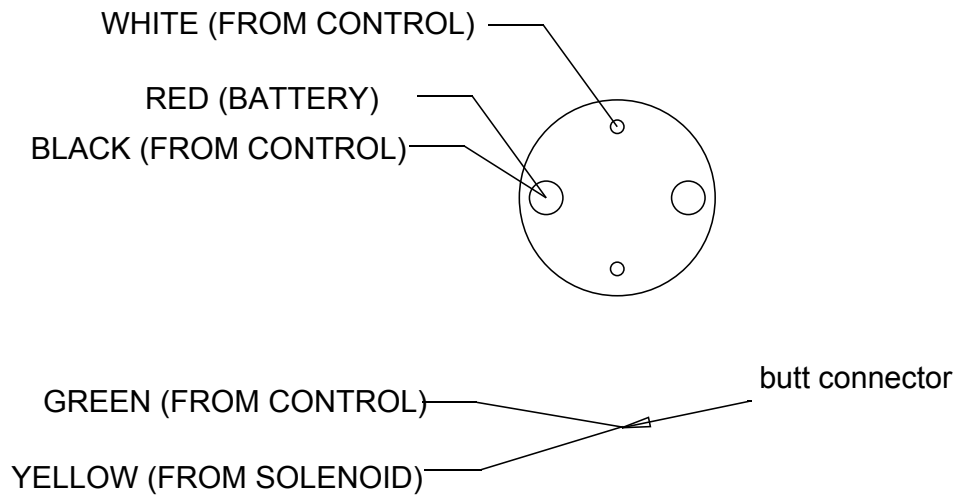

CONTROL WIRING

HYDRAULIC HOIST 64106

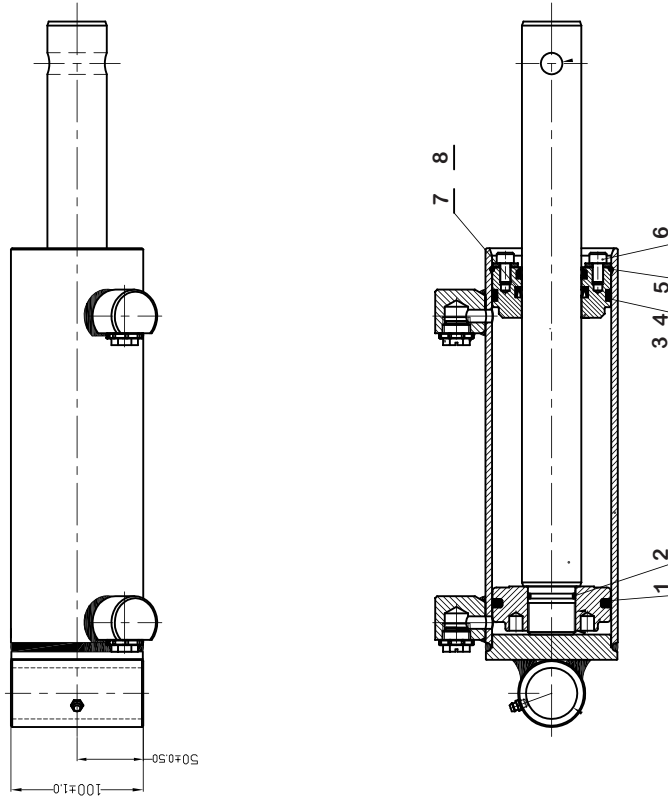

64114 SEAL KIT		
ITEM	DESCRIPTION	QTY
1	ZURCRON YWNSEAL	1
2	O-RING	1
3	O-RING	1
4	BACK-UP RING	1
5	FLAT WASHER STEEL	2
6	HEX SOCKET HEAD SET SCREW	2
7	ZURCON U-CUP RU3	1
8	SCRAPER DA17	1

HYDRAULIC HOIST CONT'D

RETURN LINE LAYOUT

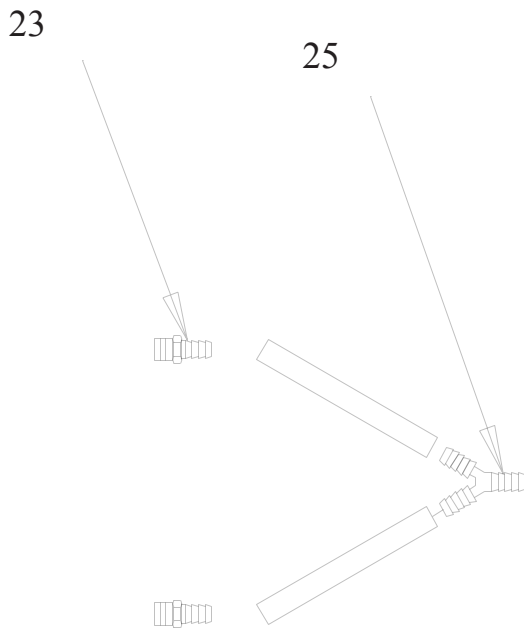

DUAL CYLINDER LINE LAYOUT

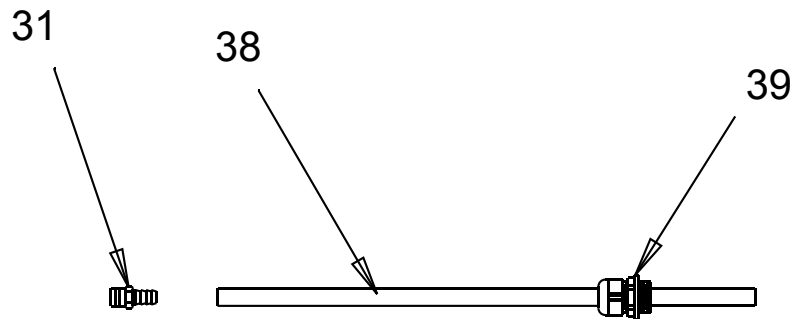

SINGLE CYLINDER LINE LAYOUT

HYDRAULIC HOIST CONT'D

SUPPLY LINE LAYOUT

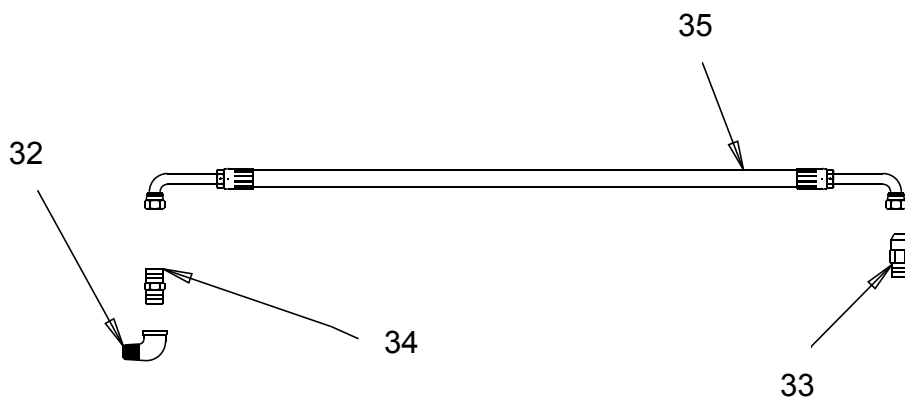
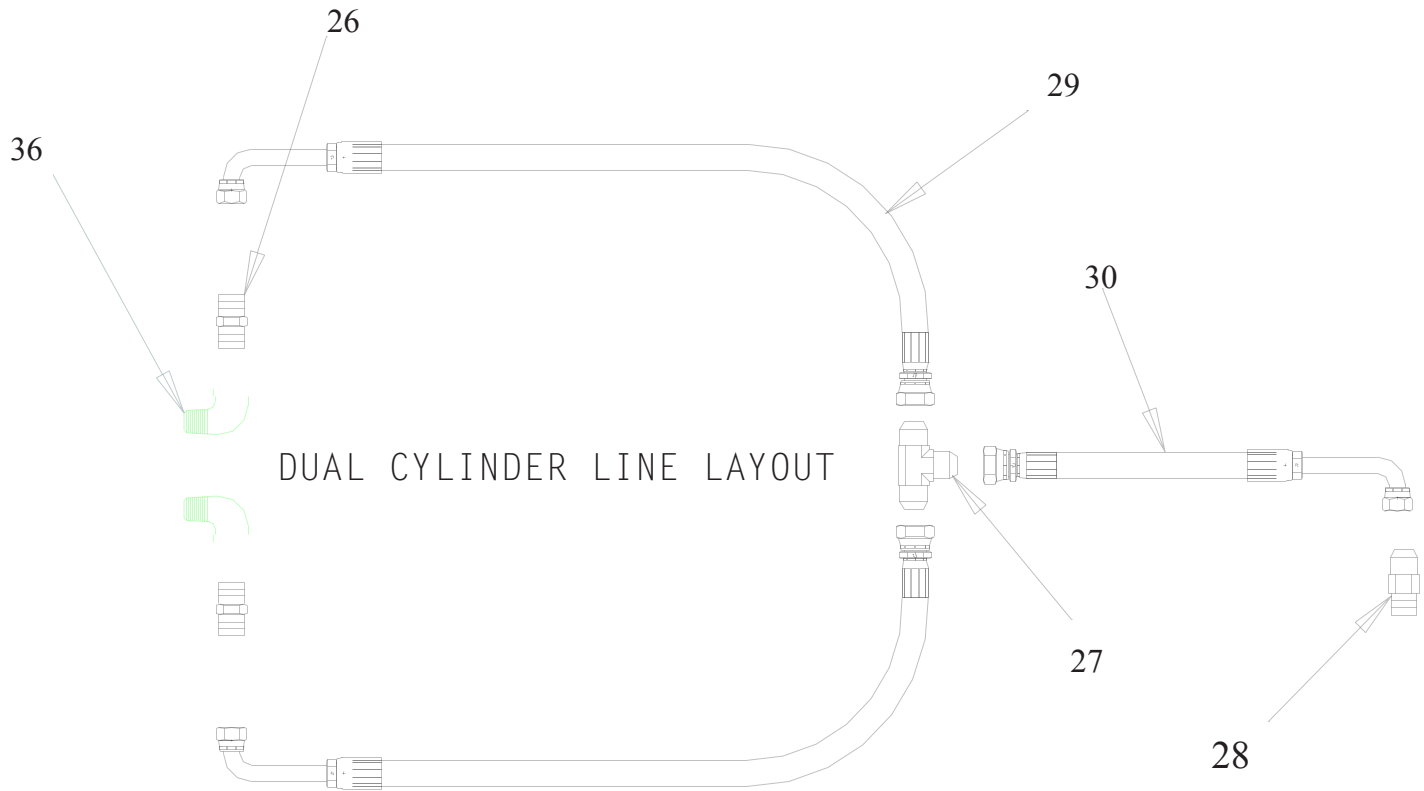

HYDRAULIC HOIST LINE PARTS LIST

ITEM	PART NUMBER	QTY	DESCRIPTION (DUAL HOIST)
21	64115	100 FT	TUBING, 3/8" ID CLEAR
22	64116	1	CORD, GRIP, 1/2"
23	64117	2	FITTING, 1/2MPT X 3/8 OD BARB
25	64118	1	Y 3/8" BARB
26	64119	2	ADAPTER, #6 JIC(M) X 1.2MPT (M)
27	64120	1	TEE #6 JIC(M)
28	64121	1	ADAPTER, #6 JIC(M) X #6 ORB
29	64122	2	HOSE, 3/8 #6 JIC(F) - #6 JIC(F) 90° 18"
30	64123	1	HOSE, 3/8 #6 JIC(F) - #6 JIC(F) 90° 38"
36	63489	2	ELBOW, 1/2" 90° STREET
ITEM	PART NUMBER	QTY	DESCRIPTION (SINGLE HOIST)
31	64117	1	FITTING, 1/2MPT X 3/8 OD BARB
34	64119	1	ADAPTER, #6 JIC(M) X 1.2MPT (M)
32	64247	1	ELBOW 90° 1/2-14 MNPT 1/2-14 FNPT
33	64212	1	ADAPTER, #6 JIC(M) X #6 ORB
35	64122	1	HOSE, 3/8 #6 JIC(F) - #6 JIC(F) 90° 18"
38	64115	1	TUBING, 3/8" ID CLEAR
39	64116	1	CORD, GRIP, 1/2"

CAB SHIELD

64251 CS

64252 S3

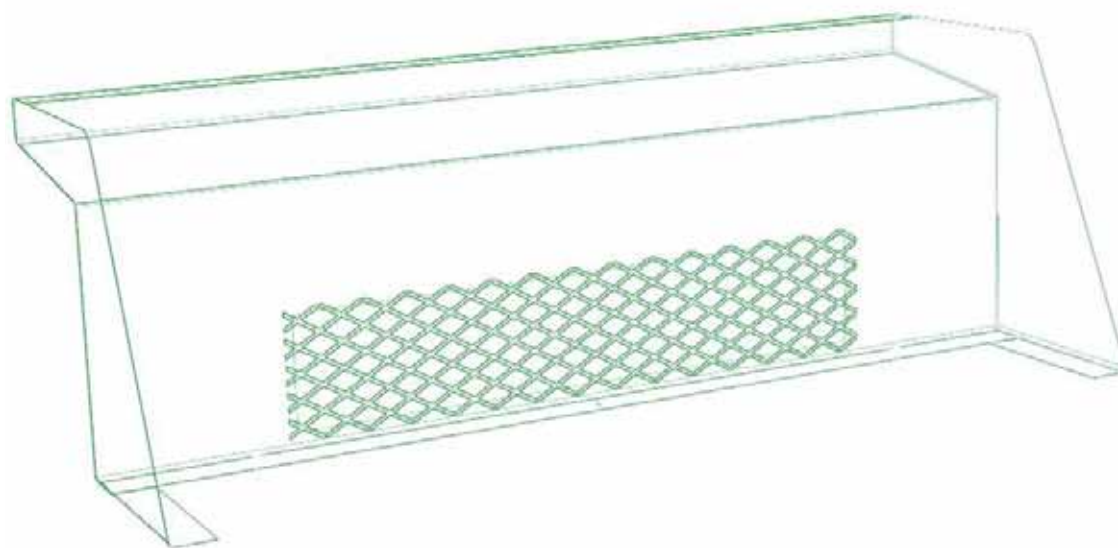

TWO YEAR WARRANTY

TWO YEAR WARRANTY

Magnum Spreader promises to the consumer to repair, or at our option to replace any part of this Magnum Spreader, accessory (other than noted below) except expendable parts such as pins, Spreader fins, and other normal wear items, which proves to be defective in workmanship or material under normal use for a period of two year's from the date of delivery to the original purchaser. During the two year's, Magnum Spreader will provide, through its Distributor / Sub-Distributor network, all labor or parts necessary to correct such defects free of charge. Faulty parts will be repaired or replaced by the Distributor / Sub-Distributor where that particular piece of equipment was purchased. Any cost incurred in returning the product to the Distributor / Sub-Distributor is the responsibility of the consumer.

EXCLUSIONS

IN NO EVENT SHALL MAGNUM SPREADER BE LIABLE FOR SPECIAL, INCIDENTAL OR CONSEQUENTIAL DAMAGES OR FOR DAMAGES RESULTING FROM LACK OF NECESSARY MAINTENANCE, FROM MISUSE, ABUSE, ACTS OF GOD, ALTERATION OF ANY PRODUCT, OR FROM USE OF PARTS NOT SUPPLIED BY MAGNUM SPREADER. USE OF THE MAGNUM SPREADER FOR ANY PURPOSE OTHER THAN SPREADING MATERIALS AS INTENDED BY MAGNUM SPREADER, IS ONE EXAMPLE OF AN ABUSE AND MISUSE OF THE PRODUCT.

WARRANTY SERVICE

In order to obtain service under this warranty, the consumer must return this product to the Distributor / Sub-Distributor from whom the product was purchased or to any authorized Magnum Spreader Distributor / Sub-Distributor, transportation and freight charges prepaid. Only Magnum Spreader Distributors / Sub-Distributors are authorized to perform the obligations under these warranties. For the address and telephone number of the Distributor / Sub-Distributor nearest you, check the telephone directory or you may write to the warrantor at the address below.

GENERAL

It is the responsibility of the consumer to establish the warranty period by verifying the original delivery date. A bill of sale, canceled check or some other appropriate payment record may be kept for that purpose. For this warranty to be effective, the consumer must Register the product on-line at www.magnumspreaders.com. No person is authorized to change this warranty or to create any warranty other than that set forth herein. This warranty gives you specific legal rights and you may also have other rights which vary from state to state.

In order to validate this warranty, please go to our web site www.magnumspreaders.com to register your new Magnum Spreader.

Magnum Spreader reserves the right, under its continuing product improvement program, to change construction or design details, specifications and prices without notice or without incurring any obligation.

Magnum Spreader
18513 Euclid Ave. • Cleveland, Ohio 44112-1084
Phone 486-1313 (Area Code 216)
www.magnumspreaders.com

© 2007 Printed in the U.S.A.



MAGNUM SPREADERS
18513 EUCLID AVE.
CLEVELAND, OHIO 44112-1084

PHONE: (216)486-1313

website: www.magnumspreaders.com

**IMPORTANT
INFORMATION
ENCLOSED**